

# BACKSCATTER MACRO WIDE 4300

## Instruction Manual

Watch our instructional video: [www.backscatter.com/MW-4300](http://www.backscatter.com/MW-4300)

### THE ULTIMATE VIDEO LIGHT FOR MACRO AND WIDE ANGLE

Thank you for your purchase of the Backscatter Macro Wide 4300 Video Light. Whether you are a seasoned underwater pro or a new shooter, we hope you enjoy your video light for years to come.

The Backscatter Macro Wide 4300 Video Light was designed by underwater videographers with underwater videographers in mind. If at any time you have any questions about your new light, how to shoot it, or best shooting techniques, don't hesitate to call us. As fellow underwater image makers, we're here to help you get the best shots possible.

### DON'T LIKE INSTRUCTIONS? WATCH OUR VIDEO!

We understand that some people never read the instructions. However, it's critical that you fully understand the safety requirements for operating the Backscatter Macro Wide 4300 Video Light. Go to [www.backscatter.com/MW-4300](http://www.backscatter.com/MW-4300) and download our latest instructional and technique videos prior to use. But for now... READ THESE INSTRUCTIONS!

### BATTERY SAFETY, INSTALLATION AND MAINTENANCE

The Backscatter Macro Wide 4300 Video Light is designed to only use high quality lithium ion 21700 batteries. NEVER USE AN UNAPPROVED 21700 BATTERY! Please see our Battery FAQ section for full details. To install a battery, twist off the battery cap, remove the double o-rings and first clean the o-rings and the grooves on the battery compartment. Lightly grease the o-rings with the provided o-ring grease and re-install the o-rings on the battery compartment. Install the approved 21700 batteries according to the diagram in the battery compartment. Inspect and clean the battery cap o-ring sealing surface, then line up the notches in the battery cap with the battery cap alignment rails in the light body and then twist the battery cap into place. See figure below. Verify you have fully twisted the battery compartment until it stops. There is no need to over tighten. IF YOU SEE WATER INTRUSION OR CORROSION IN THE BATTERY COMPARTMENT OR THE STROBE BODY, STOP USE IMMEDIATELY AND CONTACT US.

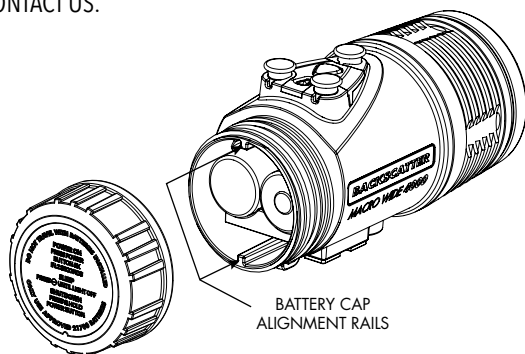

### POWER/MODE BUTTON

To power on the Backscatter Macro Wide 4300 Video Light, quickly press the POWER/MODE button 5 times within 3 seconds. To shut down the light, press and hold the POWER/MODE button. While the off mode is a safety feature, never travel with batteries installed in the Backscatter Macro Wide 4300 Video Light.

### MACRO, WIDE, AND RED MODES

There are 3 main modes on the Backscatter Macro Wide 4300 Video Light: MACRO, WIDE, and RED. To change modes, short press the POWER/MODE to cycle through the modes. There are 5 power levels for MACRO and, 3 power levels each for WIDE and RED.

**MACRO:** A tight spot beam pattern tailored specifically for macro video shooting. The tight beam results in high exposure values to maintain small apertures, low ISOs and knock out ambient light. Use this mode with the Backscatter Optical Snoot to create an even tighter focused beam to isolate critters. Also great for night diving.

**WIDE:** 4300 lumens of light for wide angle video. The color temperature of the wide angle LEDs are calibrated at the factory to ensure consistent color temperature for dual video light setups.

**RED:** Use this mode at night as a focusing light or to set up a video scene while avoiding the "swarmies". Get creative and use red mode for backlighting!

### + / ALERT BUTTON

Short press the + button to increase the light output of the light. When maximum output is reached the light will do a short blink to indicate it has reached full power.

Press and hold the ALERT button to activate a high frequency flash pattern. Release the button to return to the previously used mode. This is useful to get a diver's attention and even works well at long distances or in limited visibility.

### - / BEACON BUTTON

Short press the - button to decrease the light output of the light. The light can be decreased all the way to 0% and put in SLEEP mode to save battery power without having to shut down the main power to the light. The battery indicator will blink once per second to indicate SLEEP mode. To exit SLEEP mode, press the + button to increase the output of the light.

Press and hold the BEACON button to activate the light's signaling mode. This is useful to mark a spot where there's a good critter to shoot, marking an entry/exit point for a night dive, or for emergency signaling. There are three different BEACON modes to choose from:

**GLOW:** Slowly ramp up and ramp down the light in a slow pulsing signal. This is the default BEACON setting from the factory.

**PING:** 2 quick flashes every 2 seconds.

**SOS:** International signal for SOS.

### BATTERY STATUS LED

The Battery status LED will indicate the power level of the battery. Green is 100% to 50%, Yellow is 50% to 10%, Red is 10% to 1%. The light will shut down at lower than 1% in order to prevent overly discharging the battery.

## MACRO STATUS LED

The MACRO status LED will indicate if the macro beam is in use. The LED will indicate blue if the light is in MACRO mode. The indicator is very useful when using the Backscatter OS-1 Optical Snoot as it is very difficult to tell the difference between MACRO mode or WIDE mode with the snoot installed. The light and snoot were designed to be used in MACRO mode for the brightest output and most efficient battery use. Using the snoot with WIDE mode will result in diminished light output and more battery consumption compared to MACRO mode. For this reason always use MACRO mode with the snoot.

## CHANGE THE BEACON MODE PREFERENCE (ADVANCED SETTING)

In BEACON mode, press both + and - at the same time for 10 seconds. The battery indicator light will slow blink red.

Enter 5 digit PIN code by pressing the + and - buttons in this order:

+ - + - -

You have 3 seconds to begin entering the PIN, and the PIN must be fully entered within 5 seconds, otherwise the light exits the advanced setting mode. If a wrong PIN code is entered the light exits the advanced setting mode. When the PIN is successfully entered the battery status LED light will change to fast blink red.

Press BEACON button to cycle through the 3 different beacon patterns: Glow, Ping, or SOS.

Press and hold + and - buttons for 3 seconds to confirm the beacon mode choice and exit to the last used mode.

Press power button once at any time to exit and not save changes.

## IN THE BOX:

Backscatter Macro Wide Video Light  
YS Style Arm Mount  
Standard Ball Mount  
2X 21700 Batteries  
21700 Battery Storage Box  
Battery Charger  
2X Main Seal O-rings  
3/16 in. Allen Key  
Silicone O-ring Grease  
Instruction Manual  
Battery Warnings and Battery FAQ

See [www.backscatter.com/MW-4300](http://www.backscatter.com/MW-4300) for approved batteries and chargers.

## OPTIONAL ACCESSORIES:

- Backscatter Optical Snoot OS-1
- Color Filter System for Backscatter Mini Flash, Backscatter Macro Wide 4300 Video Light, and Backscatter Optical Snoot OS-1
- Dome Diffuser

## CONTROL SET AND INDICATOR LIGHT LAYOUT

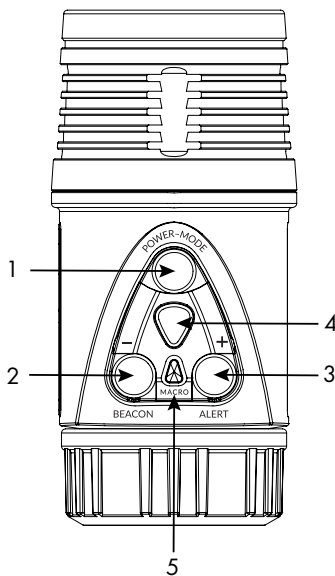

### 1 POWER/MODE BUTTON

5 quick press to power on. Press and hold to shut down. Short press to change mode.

### 2 - / BEACON BUTTON

Short press lowers light output. Long press activates BEACON mode.

### 3 + / ALERT BUTTON

Short press increases light output. Long press activates ALERT mode.

### 4 BATTERY STATUS LED

Green is 100% to 50%, Yellow is 50% to 10%, Red is 10% to 1%.

### 5 MACRO STATUS LED

Blue when in MACRO mode, off in all other modes.

## YS MOUNT INSTALLATION

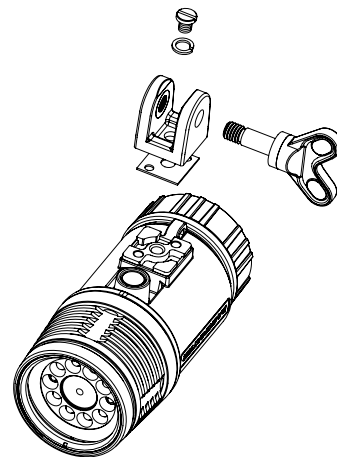

## BALL MOUNT INSTALLATION

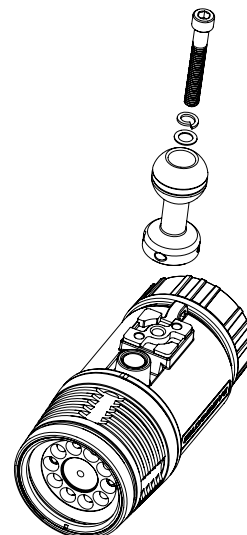

## DISTRIBUTED BY:

BACKSCATTER • +1-831-645-1082 • [sales@backscatter.com](mailto:sales@backscatter.com) • [www.backscatter.com](http://www.backscatter.com)

# BACKSCATTER

## MACRO WIDE 4300

### O-ring Maintenance Instruction Manual

Watch our instructional video: [www.backscatter.com/MW-4300](http://www.backscatter.com/MW-4300)

#### 3 LAYERS OF PROTECTION FOR YOUR SAFETY AND CONVENIENCE

The Backscatter Macro Wide 4300 has 3 layers of protection for the battery compartment seal: 2 main body o-rings and a sand seal gasket.

#### MAIN BODY O-RINGS

The 2 main body o-rings are identical so there is no worry about mixing the o-ring up or installing in the wrong order.

To maintain the o-rings, the o-rings need to be removed and inspected for any dirt, sand, hair, or any other debris and cleaned. Clean the o-rings with a lint free paper towel to remove any debris and excess o-ring grease.

Never use petroleum based cleaners, lubricants (such as WD-40), or chemicals to clean the light or the o-rings as this can damage the light and o-rings and destroy the water sealing capability of the o-rings.

After the o-rings are cleaned and inspected for any damage, lightly grease the o-rings with the provided o-ring grease. Do not over grease the o-rings as excess grease will attract debris to the o-ring. Use just enough grease to provide lubrication so that the o-ring slides through your fingers easily. Do not use other types of o-ring grease as other types of grease may be incompatible with the o-rings and destroy the water sealing capability of the o-rings, leading to damage of the light.

#### SAND SEAL

The sand seal is a gasket that will help prevent sand and other debris from the ocean environment from reaching the o-rings. This helps keep the o-rings clean and reduces the amount of o-ring maintenance that needs to be done. The sand seal is not a water tight seal, and is not designed to keep water out of the light. Never add any o-ring grease to the sand seal as this will attract sand and debris to the sand seal. To clean, simply wipe it with your finger or a lint free paper towel.

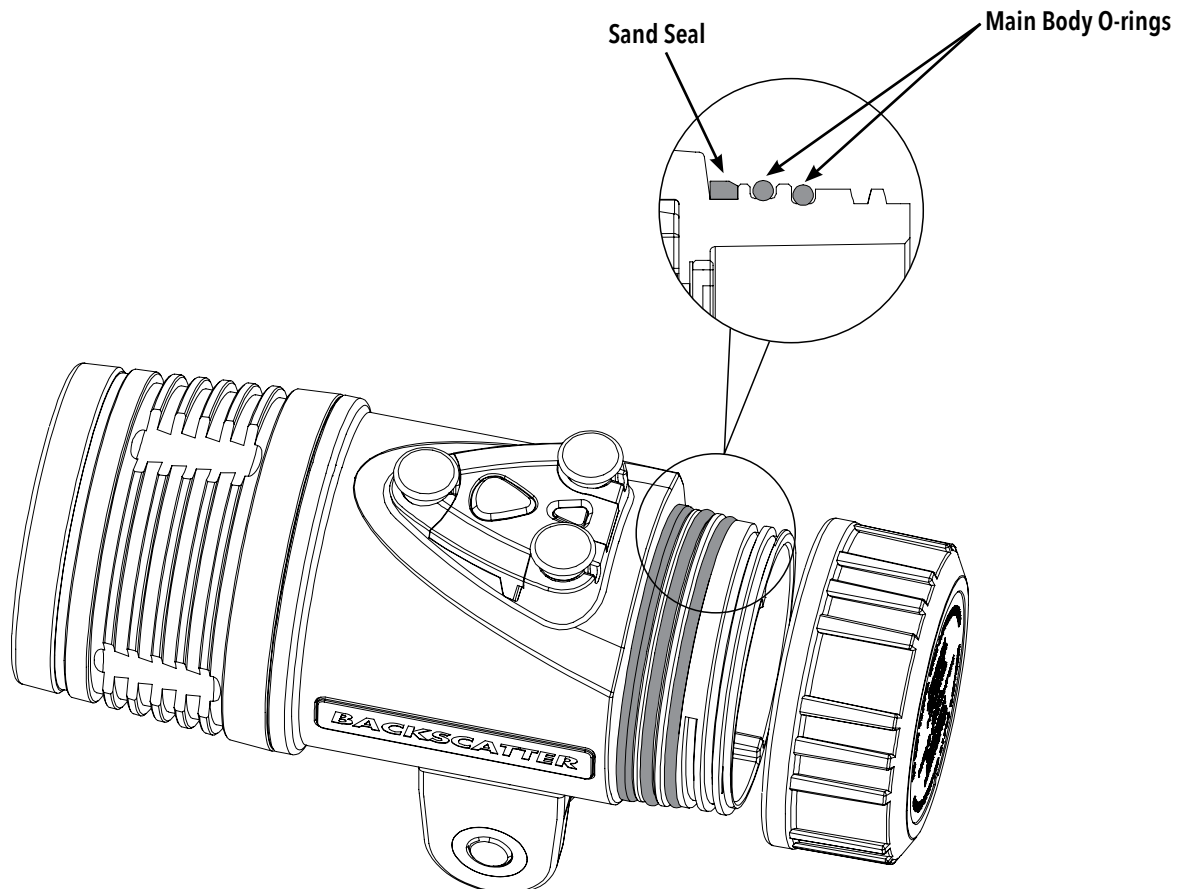

DISTRIBUTED BY:

BACKSCATTER • +1-831-645-1082 • [sales@backscatter.com](mailto:sales@backscatter.com) • [www.backscatter.com](http://www.backscatter.com)

## **Battery FAQ For Lithium Ion (Li-Ion) Batteries to use with the Backscatter Macro Wide 4300 Video Light**

A catastrophic battery accident can result in fire, explosion, injury, and death, even when all precautions have been taken. Please read the following FAQ about battery usage and safety precautions to minimize that risk.

### **What battery should I use for the Backscatter Macro Wide 4300 Video Light?**

We recommend the **Xtar 21700 5000mAh Li-Ion Battery or Nitecore NL2150HP Li-Ion 15A 21700 battery** for use with the Backscatter Macro Wide 4300 Video Light. It is the battery we developed the Macro Wide 4300 around and the only one we officially recommend for safety and proper performance of the Macro Wide 4300. The Macro Wide 4300 comes with 2 Xtar 21700 5000mAh batteries and a charger.

### **What happens if I use a different battery that doesn't conform to the same specs as the Xtar 21700 500mAh or Nitecore NL2150HP Li-Ion battery?**

Due to the high demands of power from the light, anything less than a battery rated at 15A continuous current would result in performance issues, including shutting down of the battery. The Backscatter Macro Wide 4300 Video Light is designed with safety mechanisms to prevent over discharge of the battery and will shut down if it detects a battery that can't keep up with performance.

### **I see other 21700 batteries all over the internet selling for super cheap, why can't I use those? Are you guys trying to rip me off?**

Those cheap batteries are unprotected and not designed for end use by consumers and do not have important safety protections built in. They can sometimes be identified by having no branding on the label, or by a plain single color battery jacket with dot matrix printing. Unprotected batteries without safety protections are much cheaper to produce than batteries with protection circuitry.

### **What is the difference between a "protected" battery and an "unprotected" battery, and why should I always use a protected battery?**

Protected Lithium-Ion batteries have an electronic circuit built into the battery cell packaging. This circuit protects the battery against overcharge, over discharge, short circuit, over current, and temperature. Protected batteries are safer to use than unprotected batteries that do not have these safety features built in.

Unprotected batteries have no built in safety protections for overcharge, over discharge, short circuit, over current, or temperature which can result in fire, explosion, injury, or death in the case of failure even when every precaution has been taken. Unprotected 21700 batteries are not designed for consumer use, so do not use it. Only use protected batteries designed for consumer use.

### **Why are unprotected batteries sold if there are greater safety risks versus a protected battery?**

21700 batteries are a very common and popular Li-Ion battery not only made for end use consumers but also used by manufacturers to combine multiple units into a larger battery pack for anything from flashlights to electric cars. Did you know Tesla electric cars are running on battery packs made up of thousands of 21700 batteries? It is up to those manufacturers to build in their own safety precautions for their custom designed battery packs.

### **I'm confused by all this battery geek terminology and I am still unsure of what battery to get.**

Simple! Just use the battery we recommend, the **Xtar 21700 5000mAh Li-Ion Battery or Nitecore NL2150HP Li-Ion 15A 21700 battery** available at Backscatter and other retailers worldwide.

### **Why should I always charge the battery in a common area when people are around?**

Although battery failures are rare, it can be catastrophic. The charging process is a critical operation. Most Li-Ion battery failures that occur happen during charging. Never charge in sleeping quarters, below boat decks, or in other unmonitored, or unoccupied areas. In case of emergency, you want someone around to be able to take action. While it is rare for a battery to fail when all proper safety precautions have been taken, the consequences are too great to ignore.

### **How do I store batteries when not in use?**

Batteries should be stored in a battery storage box designed specifically for 21700 batteries. A proper box will provide impact protection and keep batteries isolated so the battery contacts cannot be bridged and cause a short.

### **What do I do if the battery has physical damage or water damage?**

Immediately stop using the battery, as it is now a safety hazard. Immediate action needs to be taken to safely dispose of the battery. If at home take it immediately to an authorized battery recycling center or hazardous materials disposal site. If at a resort or a live aboard boat, notify resort management or boat captain immediately so that they may safely dispose of the battery. If on land and unable to take to an authorized battery recycling center, place it in a fireproof box and store outside in an open area away from any sources of fuel or ignition until a time when the damaged battery can be taken to an authorized battery recycling center. Never dispose of batteries in the garbage or trash. Never ship damaged batteries.

### **I suspect water has intruded the battery compartment and/or light head. What should I do?**

Immediately discontinue use of the Backscatter Macro Wide 4300 Video Light and remove the battery as soon as practically possible. Even though the Backscatter Macro Wide 4300 Video Light has a one way over pressure relief valve in case of overpressure, take extra precaution when opening as the battery compartment may be over pressurized. Use a damp towel to cover the Backscatter Macro Wide 4300 Video Light before opening to protect yourself and others.

### **If I have water intrusion into the battery compartment can I dry it out and use a new battery?**

Maybe. The battery compartment is sealed from the rest of the light for safety. After water intrusion rinse the battery cap and battery compartment of the Backscatter Macro Wide 4300 Video Light with fresh water. When the battery cap and contacts are completely dried and cleaned free of corrosion then a new battery may be installed and the Backscatter Macro Wide 4300 Video Light tested for operation. However, if there is any unusual operation of the Backscatter Macro Wide 4300 Video Light with the new battery, immediately discontinue use, remove the battery, and contact the Backscatter service department or your local Backscatter dealer.

### **Can I leave the battery installed in the Macro Wide 4300 for travel?**

NEVER travel with batteries installed in the Backscatter Macro Wide 4300 Video Light.

### **Can I travel with the batteries in my checked luggage?**

Absolutely not. It is illegal to travel with Li-Ion batteries in the cargo hold on passenger aircraft. All Li-Ion batteries must be carried on aircraft in cabin luggage in an appropriate battery box that does not allow the battery contacts to be bridged.

**Never fly with damaged batteries.** Damaged batteries are banned from ALL aircraft by law for good reason. **Do not take chances. Your life and the lives of others are not worth a cheap battery!! Dispose of damaged batteries immediately!!**

### **All this battery safety talk has me concerned.**

You should be. Following these procedures and precautions can help minimize risk greatly, but not completely eliminate it. While battery failures that cause catastrophic damage, injury, and death are very rare, it is your responsibility to use the best care possible to minimize that risk to yourself and others.

### **Safety precautions need to be taken with Li-Ion batteries.**

#### **Never do the following:**

- Never charge batteries in unattended areas.
- Never charge while sleeping.
- Never charge below decks of a boat.
- Never store batteries below decks of a boat.
- Never store batteries in the light below decks of a boat.
- Never use batteries without protection circuitry.
- Never dispose of batteries in the garbage or trash.
- Never put batteries in checked baggage when traveling.
- Never walk around with bare batteries in your pocket, especially with other metal objects than can easily bridge battery contacts.

#### **Always do the following:**

- Only charge batteries in common areas where and when others are around.
- Always remove the battery from the Macro Wide 4300 light when not in use.
- Only use batteries designed for end use by consumers with safety protection circuitry.
- Only store batteries in a battery box designed for 21700 batteries.
- Always travel with batteries in cabin baggage.

**ALWAYS OBEY ALL INSTRUCTIONS FROM THE BATTERY MANUFACTURER**

# BACKSCATTER OPTICAL SNOOT

## Instruction Manual

### THE ULTIMATE STROBE AND SNOOT COMBINATION

Thank you for your purchase of the Backscatter Optical Snoot OS-1. Whether you are a seasoned underwater pro or a new shooter, we hope you enjoy your snoot for years to come.

The Backscatter Optical Snoot was designed together with the Backscatter Mini Flash to be the easiest to use strobe and snoot combination possible. Snoot photography can result in some of the most rewarding and creative shots, but can also be a little challenging, particularly for new shooters. If at anytime you have any questions about how to use your new snoot or best shooting techniques, don't hesitate to call us. As fellow underwater photographers, we're here to help you get the best shots possible.

### DON'T LIKE INSTRUCTIONS? WATCH OUR VIDEO!

We understand that some people never read the instructions. While the operation of the OS-1 is fairly straightforward, these instructions will provide some basic techniques to get you up and running. For more hands on instruction please watch our video at [www.backscatter.com/MF-1](http://www.backscatter.com/MF-1) that shows the best techniques to get the most out of your new snoot.

### SNOOT INSTALLATION WITH THE MF-1

Simply push the rubber boot of the snoot straight on to the front of the MF-1 until it clicks and locks into place. To uninstall the snoot, grab the snoot and pull it slightly to the side to release the rubber boot from the front of the MF-1.

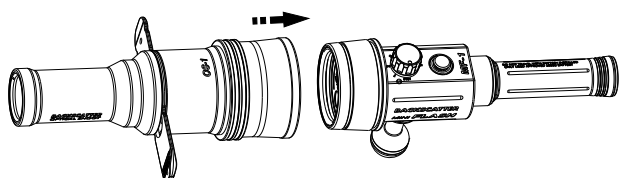

### INSTALLATION OF THE APERTURE CARD

The aperture cards allow you to change the size of the beam of light coming from the snoot to better tailor the light to the size of the subject. There are two aperture cards included, one with circles, one with ovals. Each has 4 settings. The snoot can be used without an aperture card, giving it a total of 5 different beam settings. Insert the aperture card in the slot just behind the optical section of the snoot near the lanyard attachment. Slide the aperture card into the desired position. The aperture card will click into place.

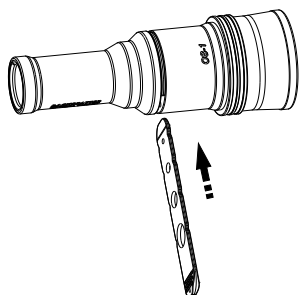

### SHOOTING TIPS

Use the LED lights of the MF-1 to see where the flash will hit. The LED light beam will project the exact same beam as the flash giving an accurate aiming light to line up the subject.

Frame up the composition first, then move the snoot into position to light the subject.

The minimum usable distance from the subject to the snoot is about 70mm in water. This distance will produce a focused, sharp edge to the beam. If you are practicing on land the distance to produce a sharp edge to the beam will be closer than in water.

If you want to have a softer edge to the light, move the snoot a little further away from the subject.

If you have the option to use a larger aperture hole at a closer distance, this will transmit more light than a smaller hole at a longer distance.

Use the oval aperture card for longer subjects like nudibranchs and long slender fish to better tailor the light to the subject.

With the oval aperture card installed and the snoot at an angle to the subject, the snoot can be rotated to either elongate the oval shape or return the shape to a circle.

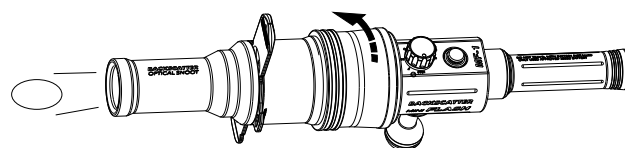
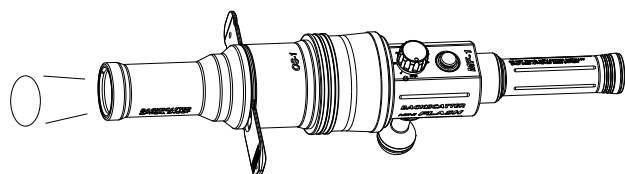

Rotate the snoot to change the beam shape

This manual is available in other languages at [www.backscatter.com/MF-1](http://www.backscatter.com/MF-1)

### DISTRIBUTED BY:

BACKSCATTER • +1-831-645-1082 • [sales@backscatter.com](mailto:sales@backscatter.com) • [www.backscatter.com](http://www.backscatter.com)